

SYMETIX[®]

Automation for Tablet Integrity

Impulse/p[™] high-capacity size grader



Designed specifically for solid-dose pharmaceutical and nutraceutical manufacturers, Impulse/p[™] vibratory size graders combine gentle electromagnetic power and high-speed/high-throughput design to maximize tablet quality.

This high-capacity machine is specifically configured to remove broken tablets – while saving labor costs, enabling five-minute changeover and integrating smoothly with other automation.

- **Capacity** of 1,000,000 tablets per hour
- **Handles** oblong tablets
- **Two removable decks** for each tablet length
 - Removes 90% of broken tablets
 - Maximum loss of good tablets – 0.15%
- **Solid state magnetic drive**, oil-free operation
- **Stand-alone control panel** with touch screen or master control panel in a complete line
- **Large infeed hopper, electronically controlled infeed gate** – convenient interface to other automation
- **Ideal for feeding VeriSym[®]** Optical Inspection Systems
- **Simple, fast to clean and clear** – 5-minute changeover



Impulse/p[™]

high-capacity size grader

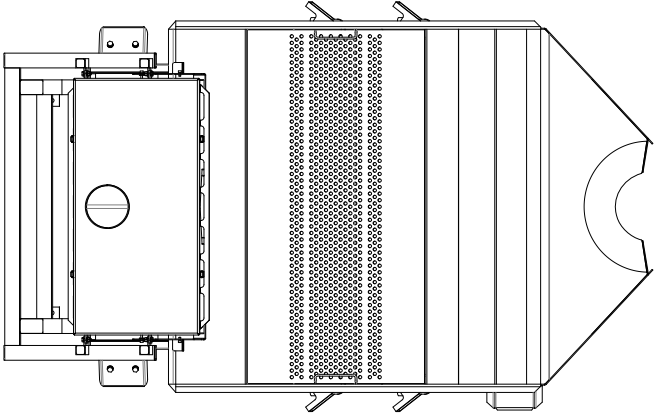

Overall Length 87" (2210 mm)

Overall Width 55" (1397 mm)

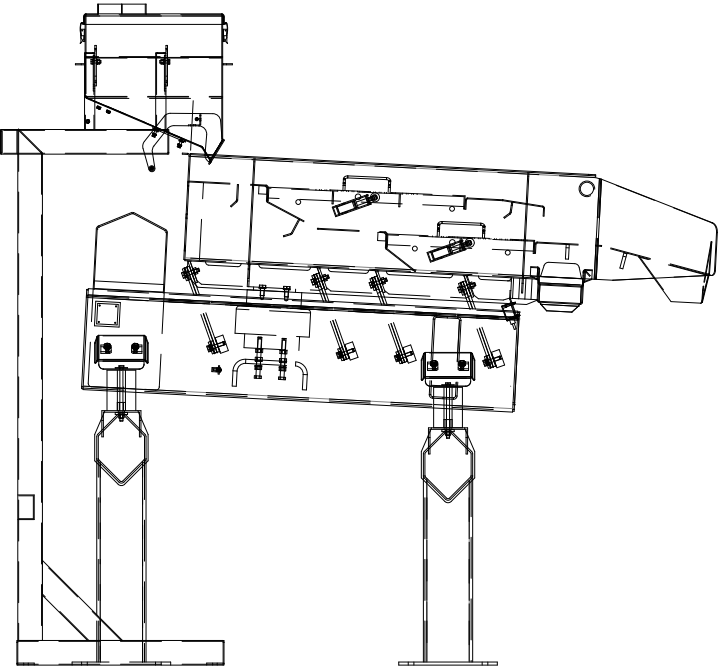

2-Deck Configuration
for Tablet Grading

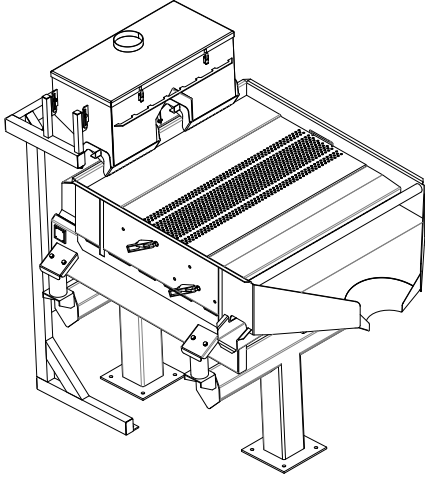

Utility requirements

Electrical: 10 Amps, 1 Phase
50/60 Hz, 200 - 230 VAC